

SYNOX® PF

PRECOAT CANDLE FILTER

For filtration of beverages and other sensitive liquids



The latest generation of precoat filters, presented by the market leader.

The SYNOX® filter is suitable for all kind of precoat filtration, typical applications include filtration of beer, wine, beverages in general, syrups, gelatin, liquid food components. Basically any liquid solid separation where hygienic requirements exist.

Characteristics

- 25 mm STABOX® candle, completely in st. steel. ensures high pack density, reduced void volume and best utilization of slurry space, 25 % more filter area compared to previous models reduces product loss by substantially reduced interface volumes
- Patented dual path inlet distributor «JETCONTROL II». The adjustable flow pattern allows optimal distribution results, both for conventional kieselguhr and alternative regenerable filter aids
- Homogeneous particle size distribution of the filter cake
- Enhanced internal cleaning system by a system of distributed, rotating miniature spray heads, enhances the cleaning effect and reduces wash water consumption
- Hygienic gaskets according to EHEDG guidelines



Technical data

SYNOX® PF size	Filter area Sqm	Sludge holding capacity litres	Vessel volume in hl	Operating pressure
800	12 – 22	300 – 460	8,5 / 11,5	7 bar / 100°C
1100	24 – 46	640 – 1010	17 / 21 / 23	7 bar / 100°C
1300	45 – 70	1150 – 1500	29 / 32 / 34	7 bar / 100°C
1500	67 – 95	1670 – 2090	42 / 44 / 47	9 bar / 100°C
1800	90 – 139	2270 – 3020	59 / 62 / 65 / 69	9 bar / 100°C
2000	121 – 175	3080 – 3770	79 / 83 / 88	9 bar / 100°C
2300	153 – 237	3870 – 5130	104 / 109 / 114 / 121	9 bar / 100°C

Main dimensions

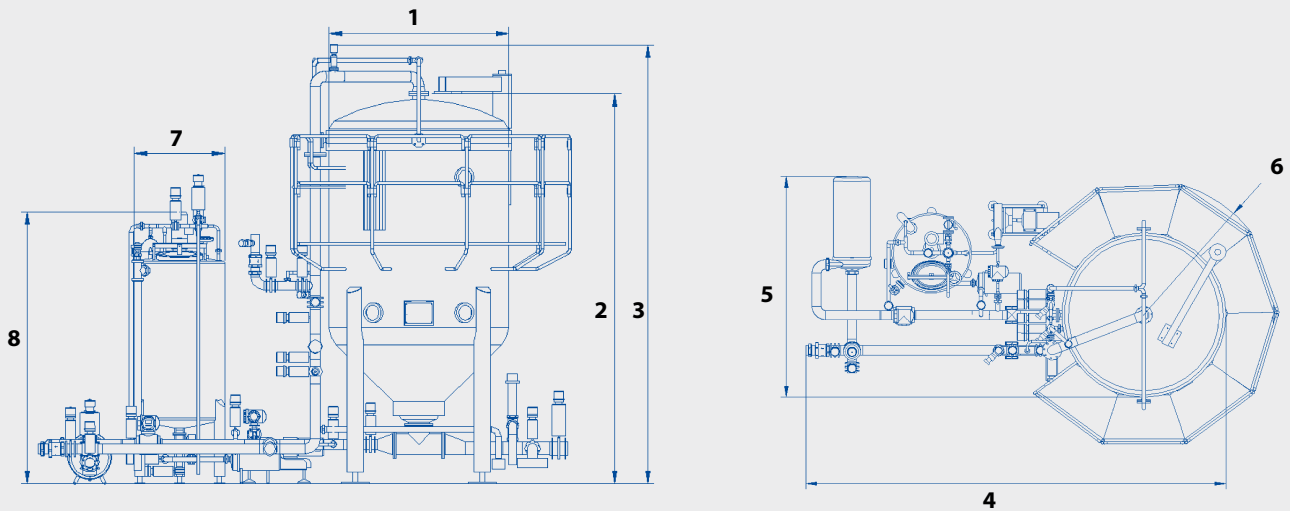

Dimensions candle filter (mm)

SYNOX® PF	1	2	3	4	5	6
800 / 250G	800	3156	3543	3100	1700	–
1100 / 500G	1120	3544	3931	3500	1900	–
1300 / 500G	1300	3829	4235	3800	2000	1291
1500 / 500G	1500	3999	4444	4000	2200	1390
1800 / 800G	1800	4221	4665	4500	2500	1540
2000 / 800G	2000	4385	4933	4700	2700	1641
2300 / 1100G	2300	4638	5228	5200	3000	1790

Technical data and dimensions dosing unit

DOSIMAT®	Volume (litres)	7 Diameter (mm)	8 Height (mm)
250 G	250	906	1720
500 G	500	906	2220
800 G	800	906	2720
1100 G	1100	1256	2425
1700 G	1700	1256	2925
2500 G	2500	1256	3425
4000 G	4000	2010	3185
6000 G	6000	2010	3685
9000 G	9000	2010	4185
12000 G	12000	2300	4745

Options

- Built on lid lifting device allows easy swiveling of filter lid for inspection purposes, available for models 1300 – 2000 (2300 with chain hoist)
- Service platform for easy access during servicing and inspection (available for models 1300 – 2300)
- Emergency pump system with battery back up

Pressure vessel certifications

The SYNOX® pressure filter vessel is available according to the following pressure vessel codes:

- European pressure vessel directive ped
- ASME, U-Stamps, section VIII, div. 1
- Chinese pressure vessel and boiler certificate
- Gosgortechnadzor

Specifications

- Vessel: St.Steel 1.4306 / AISI 304 L
- STABOX® candles: St.Steel 1.4435 / AISI 316 L
- Other materials for special applications upon request
- Valves and components: According to customer specification
- Piping: Metric according to DIN 11850, OD/ ISO/ SCHED #5 Piping upon request